

*P L A T I N U M*





**RIVIERA**









The art of great design, refined.









" Creating the Platinum Edition was a rare opportunity to introduce more luxury, style and truly inspired design; a challenge our acclaimed design team has relished."

*Rodney Longhurst - Owner Riviera*







## Take in a masterful piece of design

**R**iviera sport yachts are designed to turn heads. Their sleek aerodynamic lines attract comment and more than a little admiration at the world's finest marinas. The Riviera 5400 Sport Yacht Platinum Edition exhibits an even rarer charisma.

The exterior colour palette of silver, black and white highlights its flowing elegant contours. This is design that speaks of luxury, power and exotic destinations. Design made to be appreciated and seen.

Topping it all off, the Riviera Platinum Silver hardtop and targa meld with the enormous black wrap-around windshield, rakish black boot stripe and full length black hull windows to lend an air of sophisticated mystery.















## A sport yacht born to shine

**S**ymmetry. Luxury. Thrilling aerodynamics. Rugged practicality. The Riviera 5400 Sport Yacht Platinum Edition has it all in just the right proportions. She is the creation of an acclaimed design team charged with building on the best to create a superior sport yacht experience.

To begin with, consider all the space and style on display. You have an uninterrupted eyeline from the forward deck all the way aft to the soaring saloon space and out onto the generous broad cockpit. That's an enormous area to unwind and connect in, surrounded by Riviera luxury.

Speaking of luxury, the Platinum Edition introduces a new benchmark for gracious sport yacht living with many new refinements and innovations. The accommodation deck is the last word in designer comfort, style and attention to detail.

Flying you to your next destination are state-of-the-art twin Volvo Penta IPS 950 Inboard Propulsion System (IPS) diesel engines.



## Come aboard

**S**tep aboard, the wide hydraulic boarding platform is teak-laid with a classic recessed swim ladder and cover hatch. A touch button tender garage lies forward, with an electric winch for easy tender launch or retrieval.

Now open the gleaming stainless steel transom gates and step out onto the alfresco cockpit. That's timeless teak decking at your feet. The sporty hardtop overhead promises shade, shelter and something else besides: an electric touch button sunroof.

Take your place in the large plush, forward-facing transom lounge and consider all before you. Turning up the volume on the stereo with two weatherproof cockpit speakers. Family and friends luxuriate in the large L-shaped lounge forward to starboard, while tasty delights served from the dual electric BBQ and wet bar located to port fill their hi/lo teak table.













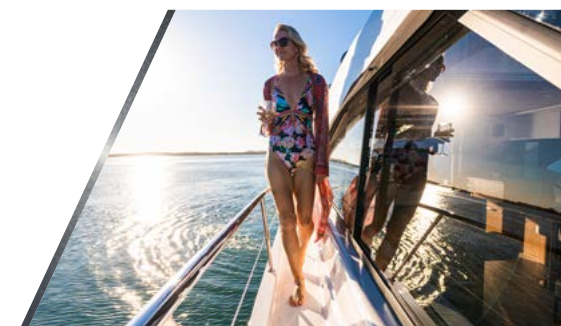

## Safety for all

**M**aking your way to the expansive forward deck is a breeze. Wide walkaround side decks, raised bulwarks, stainless steel side rails and thoughtfully positioned hand rails make for safe, easy passage, even for children and pets.

Deep foredeck lockers conceal a range of equipment where you need it. This large attractive area also doubles as a nature lover's or entertainment hot spot. Be the first to spot a pod of dolphins. Or farewell the day over a round of refreshing sundowners.

Look forward to lazing back on a double-sized sun pad with adjustable backrests and fold-up bimini. You can always pump up the foredeck volume via two weatherproof speakers located under the windscreen brow.



## The galley you want

**G**reat design makes every area of the 5400 Platinum Edition shine. Consider the ideally positioned galley. Simply open the ship-like bulkhead door and aft-facing awning window to position the chef at one with the interconnected saloon and alfresco cockpit activity. Trading conversation and gourmet treats.

The galley itself is U-shaped, generous in size and off to the side of all fore and aft traffic. But the inspired layout is far from the only refinement on show. You'll relish a quality and level of galley appointments rarely experienced offshore. Now, every dish is made easier and no meal out of reach.

In the 5400 Platinum Edition, this space boasts even more generous storage, stunning new waterfall benchtops, highly polished walnut cabinetry and the latest designer European appliances.















## Panoramic surroundings

**S**weeping glass capture ever changing views. A thousand prime destinations slide by outside. Light, space and an air of genuine luxury prevails inside. This...is...living.

Every luxury is at your fingertips: reverse cycle air conditioning, push button electric sunroof or open the tinted and tempered glass side windows for fresh sea air. A refreshing drink may be in order. You'll find the fully appointed cocktail cabinet to port, adjacent to dual fridges with stainless steel drawers and built-in wine cooler. Cheers.

Adjourn to the luxuriously large, L-shaped leather lounge also to port set around a polished, handcrafted timber dining table. (An electric hi-lo table which can cleverly reform as a day bed is optional.) To help you unwind in style, turn to the large LED television on its electric swing arm, complete with Blu ray and 5-speaker surround sound.





## Everything is at your command

**S**kippering such a spirited sport yacht is more thrilling than you can imagine and far easier than you think. If you can drive a luxury modern car you can skipper this yacht.

Those large display touch screens on the dash in front are the key. They're intuitive, easy to read, monitor and operate. At a glance, they will inform and guide you through all you need to know: vessel controls, engine system monitoring and Volvo Penta Glass Cockpit navigation.

What a thrill you're in for when you slide into the ergonomic alcantara and leather skipper's chair and take hold of the sports car like steering wheel. At your command are class-leading Volvo Penta D11 engines powering twin pod drives that deliver silky smooth, breathtaking performance. Importantly for a sport yacht of this size, joystick maneuverability gives you highly-accurate control, even reversing into tight marina berths.















## Your private retreat

**Y**ou notice design highlights everywhere onboard. Taking the companionway steps down from the saloon you look up and the soaring glass atrium above lifts your spirits and fills this whole area with light.

The master stateroom below is elegant and regally sized, luxuriating across the full beam. Private and self contained it boasts spectacular views to both port and starboard. The island bed is king-sized and supremely comfortable and matching bedside tables highlight the space on offer. There is even room for a private chaise lounge to starboard.

Deep plush pile carpet and fabulous timber cabinetry for storage including his and hers cedar-lined hanging lockers, speak of a rare luxury. There is no finer place to settle back and enjoy your world class, fully integrated home theatre system.

Every area on the 5400 Sport Yacht Platinum Edition shines, not least the master bathroom. Located forward to port it has all the luxury touches you might expect, and then a few more.

Spacious like the accompanying stateroom, it features a generous frameless glass shower stall, solid surface bench tops, above vanity basin and quality mixer tapware. Its stainless steel encased porthole can be opened to fill the space with fresh sea air and sunlight. Lovely. But if left open too long, an alarm sounds in the helm for safekeeping.

That typifies Riviera design sense and attention to detail.





## Luxury for all

**W**e know you want only the best for your guests, so welcome to the forward located VIP stateroom. Picture master-like luxury and comfort. Large walk around, queen sized island bed, reverse cycle air conditioning and high quality entertainment centre with LED TV, DVD and iPod interface.

Sweeping hull windows frame glorious views. Plush pile carpet cushions feet. And storage needs are taken care of, in style. There is a cedar lined hanging locker to port, a cedar lined starboard storage locker with shelves and outboard storage cabinets with positive locking hardware.

As in the master, your guests have private access to a superb designer ensuite which also cleverly doubles as the day head.

Located to port is the third stateroom, ideal for accommodating children, grandchildren and extra guests in keynote Platinum comfort.

After spending long fun-filled days on deck, the adult-sized upper and lower berths promise sweet dreams and restorative sleep. Your guests will wake up refreshed, step onto plush pile carpet and open their fragrant, cedar lined hanging locker housing that day's clothes. Next stop, breakfast alfresco in the cockpit.









## Engineering par excellence

**A**ccess to the flow-coated engine room — with acoustic and thermal insulation and LED lighting — is via a deck hatch from the cockpit or through a watertight door from the versatile utility area. Here you will quickly realise why Riviera is renowned globally for its engine room design.

The impressive commercial air intake system helps to keep the engine room temperature well below the manufacturer's formal recommendation, further reducing fuel consumption. Air conditioning units are mounted high so gravity feeds condensation water into the common drain lines located on either side of the yacht draining aft and overboard.

All onboard drains also feed into these common drain lines while the advanced mist elimination system with veins draws moisture from the air and feeds directly overboard. Four automatic bilge pumps with manual override are located at various points throughout the hull and pump directly overboard.

There is even a dedicated space for a gyroscopic stabiliser — another example of how Riviera is ready to embrace innovation to make boating even more enjoyable





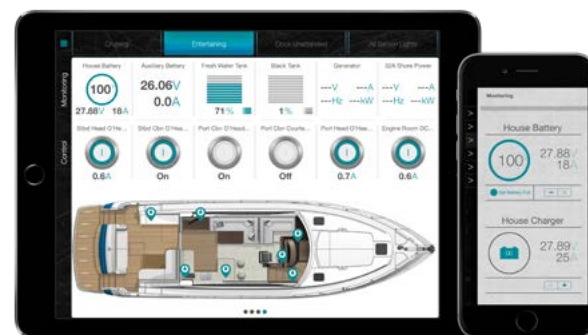

## Electrical excellence

All batteries onboard the 5400 Sport Yacht Platinum Edition are maintenance-free to ensure carefree boating and are housed in special battery boxes in accordance with American Boating and Yacht Council (ABYC) and the European Union's CE industry standards.

The house power is 24-volt, which allows for simpler charging, lower current draw and smaller cables (further reduced weight) than equivalent 12-volt systems. The Mastervolt inverter provides power to the icemaker, entertainment systems and all outlets onboard, ensuring watching television while relaxing quietly at anchor is whisper-quiet.

LED lighting is utilised throughout and provides trouble-free boating while reducing electrical current draw. The lamps use less than 10 per cent of the power required to run a halogen lamp — no bulbs mean no maintenance and long service life. Additionally, Residual Current Device/Ground Fault Circuit Interrupter (RCD/GFCI) provides protection over the entire yacht and also complies with ABYC and CE standards.



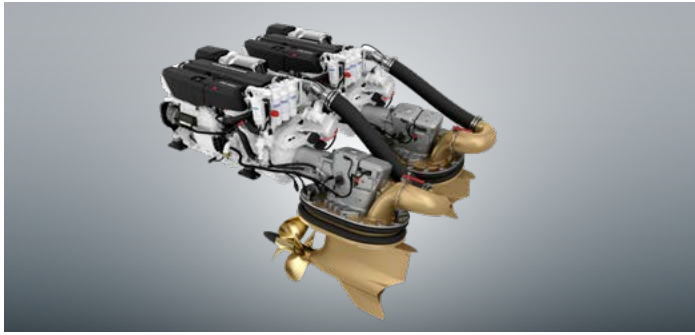

## The power and technology

Riviera is at the forefront of a marine propulsion revolution, having now launched over 500 pod-driven luxury motor yachts.

Pods are used on such worldly form vessels as the Queen Mary II cruise ship as well as large-scale commercial craft. This proven technology is now revolutionising pleasure yachts.

Pod drives offer an excellent power-to-weight ratio delivering improved performance, enhanced torque, exceptional fuel efficiency, simple maneuverability, reduced environmental impact and quiet operation thanks to under-water exhausts.

In simplified terms, Volvo Penta's innovative Inboard Propulsion System (IPS) features twin pod-drive units, each of which is capable of turning independently to provide the correct thrust to move the yacht in the exact direction required by the skipper easily controlling the system with either a steering wheel and throttles or a joystick.

The 5400 Sport Yacht Platinum Edition has a joystick at the helm and an additional joystick as standard in her cockpit which can be located on either the port or starboard sides.

IPS also offers a Dynamic Positioning System (DPS) for station-holding while preparing lines and fenders or while waiting off a fuel jetty, the convenience of Auto Pilot, manual trimming with optional auto-trim, as well as a highly-efficient Anti-Corrosion Protection (ACP) unit mounted to the transom to reduce the maintenance of sacrificial anodes.

The three-blade nibral, forward-facing, counter-rotating propellers



are protected by the premium anti-foul coating Propspeed to achieve a long service life, as well as 316 marine-grade stainless steel line-cutters from Volvo Penta, located between the propellers for protection from, fishing lines, plastic bags or nets. These precision-made line-cutters create a very efficient rotating cutting action to protect the propellers and shaft sealing without increasing drag or fuel burn.

The 5400 employs the revolutionary Volvo Penta D11-IPS800 propulsion system with twin D11 engines and IPS20 pod-drives (2x) 460kW/626hp) as the standard package. This is a perfectly matched drive package for the 5400 and the system's Class 4 commercial rating assures reliability and durability.

Additionally, the IPS2 package is fully certified under the Det Norske Veritas and Germanischer Lloyd (DNV GL) classification system.

Owners are also able to select the optional D11-IPS950 system with twin D11 engines and IPS20 pod-drive units (2 x 533kW/725hp).



## Window to the future

To give you total command of the 5400 Sport Yacht Platinum Edition, Volvo Penta's state-of-the-art Glass Cockpit navigation and monitoring system blends new technology with dependability and practical functionality.

The Glass Cockpit system provides a very clean, easy-to-use system with enhanced overview and control of both engines and navigation, including GPS, sounder and radar, even auto-pilot and optional charts ... all in one place and in the one system.

Integrated with the IPS Electronic Vessel Control (EVC) system, the Glass Cockpit gathers all driver information and displays it in one location. The easy-to-handle, pinch-to-zoom displays give you instant data and control. The ergonomic design and interface for the dashboard offers push-buttons on the controls and touch-buttons on the screens.

Just one clever feature of the Glass Cockpit is the unique Auto Guidance feature that – based on the yacht's draft and your desired safety distance to obstacles — searches through all relevant charts to create a safe route you can follow — and avoid shallow water, buoys and other known obstacles. Coupled with the Auto Pilot, it not only shows the way, it can take you there.

The Glass Cockpit also enables the option of full joystick steering whilst underway.





## The Riviera advantage

Riviera is continuing to lead the luxury motor yacht market and proudly stands behind the machinery and systems onboard its world-class designs.

A 5-year limited warranty on all Volvo Penta systems is now standard with every new Riviera and covers Volvo Penta helm station electronics, steering and propellers as well as major componentry of their high performance drivelines and fuel-efficient engines.

Available worldwide, this extended warranty compliments the Riviera 5-year structural limited warranty and will provide even greater peace of mind for our valued members of the Riviera boating family.

Riviera Family members also enjoy exclusive invitations to fun-filled social and boating education events, inspiring cruising experiences as well as special offers on genuine parts, electronics and our premium Riviera lifestyle collection.



## CZone simplicity

The fully integrated CZone digital switching system enhances the ease of monitoring and operation of the Riviera 5400's onboard systems including tanks, and extends centralised, touch-screen control to lighting, pumps, batteries, entertainment and appliances.

CZone allows owners to operate multiple circuits at a single touch, energising all lighting and electrics depending on your requirements. It comes pre-programmed with three modes — “entertaining”, “cruising” and “dock unattended” — and these modes can be customised by the owner so the system works exactly how you want.

Other user-friendly features include interior light-dimming, timer controls, automated circuit control, wiper speed and wash functions. There's also a “service” mode that shuts down all power and systems.

Based on industry-proven Controller Area Network (CAN) technology, the CZone system offers DC and AC switching and over-current protection. Full systems monitoring (with alarms) including AC voltage, current, frequency and kilowatts, DC voltage, current and remaining battery capacity, along with fluid tank levels and indication for systems in operation, is clearly displayed on the 5-inch touchscreen at the helm and 8.5-inch colour control screen at the saloon entrance.

There's also the option of additional iPad connectivity, so you can control CZone from anywhere onboard your yacht.



## Impeccable pedigree

The confident poise of the 5400 Sport Yacht Platinum Edition is just as evident offshore as it is at anchor — her solid and robust hull with keel is the evolution of our rich 39-year history of building over 5,400 world-class luxury motor yachts that are time proven in the often challenging Australian offshore conditions.

Every Riviera built at our world-class facility on Australia's Gold Coast combines superior-strength hand lay-ups with a water-tight collision bulkhead forward and independent compartments throughout the hull.

Our legendary build quality also features vinylester resin in the outer layer of lamination to increase the ability to withstand water absorption. An isophthalic gelcoat exterior provides an impeccable and hard-wearing surface finish.

From the waterline down, the hull is solid GRP with reinforced bottom, keel and chines. Structural core material is used in the hull flanks, main deck and hardtop, while precisely fitted, lightweight resin transfer-moulded small parts have a double-sided gelcoat finish and are pre-fitted for a perfect seal when all major components are bonded together.

Riviera only uses 316 marine grade stainless steel in all our exterior fastenings. All stainless steel rails feature ground and polished welds to ensure a consistently smooth and mirror finish.

Our designers have also placed a firm focus on convenient access to every key maintenance point so any issues can be quickly identified and addressed, and service costs are kept to a minimum.



# Riviera 5400 Sport Yacht Platinum Edition

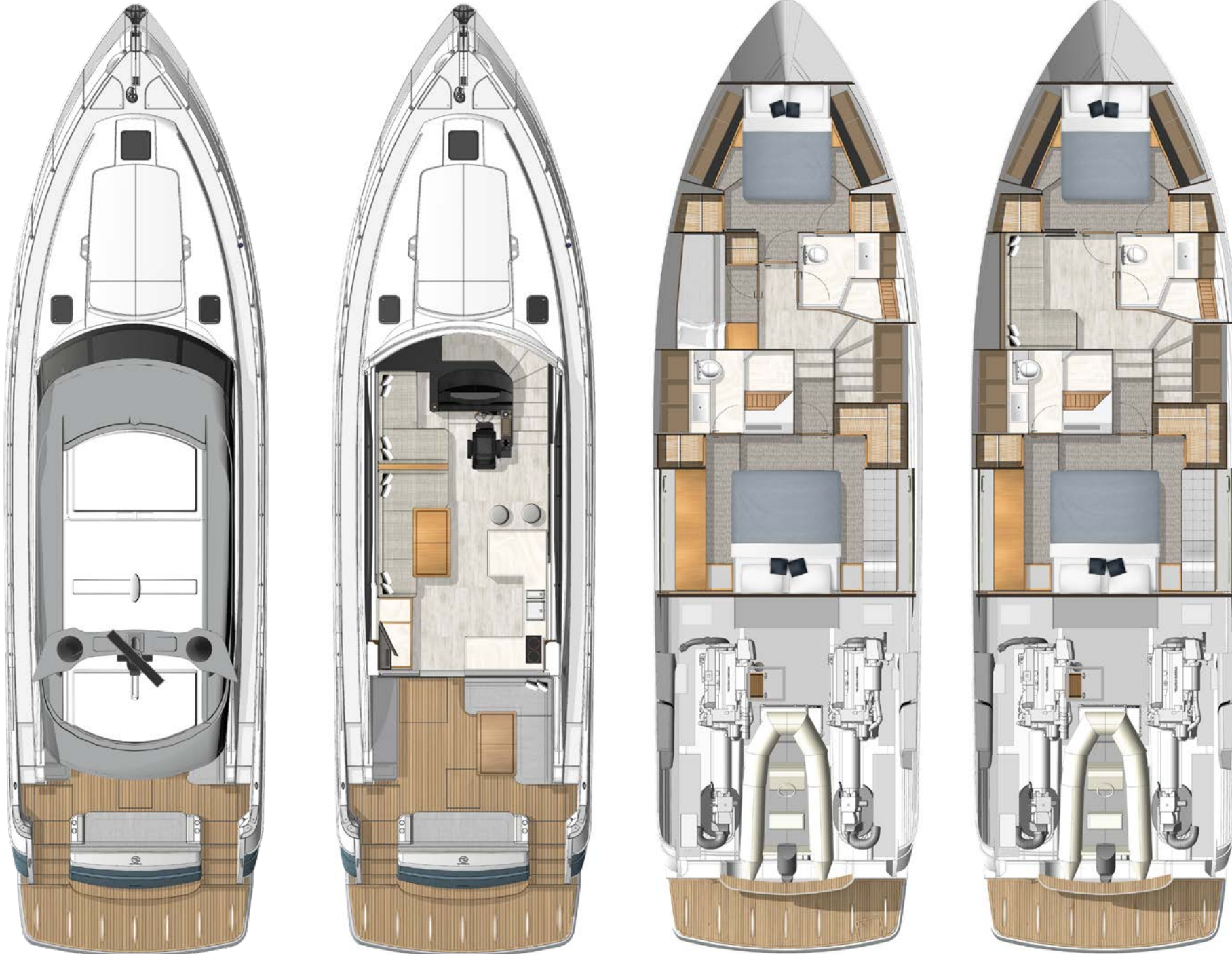

Optional lower lounge design



## Specifications

Length Overall <small>(inc. swim platform and bow sprit)</small>	17.46 m	57' 3"
Hull Length (Lh to ISO8666) *	15.93 m	52' 3"
Beam <small>(inc. gunwale)</small>	4.88 m	16'
Maximum Draft <small>(inc. props)</small>	1.45 m	4' 9"
Dry Weight <small>(approx.) **</small>	24,752 kg	54,569 lb
Fuel Capacity ***	3,000 L	793 US gal
Water Capacity ***	800 L	211 US gal
Holding Tank Capacity ***	400 L	106 US gal
Sleeping Capacity	6 persons	
Cockpit Area	9.87 m <sup>2</sup>	106.24 ft <sup>2</sup>
Bridge Clearance	5.05 m	16' 7"
Standard Engines		
Volvo Penta D11 IPS 950 x 2	533 kW	725 hp each

\*Specifications may vary on a regional basis.

## Specification clarification

\* Length of the hull (Lh) to ISO8666: Includes all structural and integral parts (ie. the moulded length of the hull). It excludes parts that can be removed in a non-destructive manner without affecting the structural integrity of the craft, (eg. pulpits, outdrives, driving platforms, rubbing strakes).

\*\* Dry weight represents the estimated minimum weight of a yacht with standard engines and options, no fuel or water on board, no equipment or provisions and no personnel. The stated dry weight may be exceeded.

\*\*\* Denotes net tank capacity. For useable capacity do not rely on more than 90% of tank capacity. Actual capacity will vary according to yacht trim and sea state. Speeds are subject to normal weather conditions, fuel and/or water levels, passengers and equipment loads.

## Our care for your information

Due to the constant refinement of specifications and design by Riviera Australia, the information in this document may change without notice. Specifications may vary with time and by region. Some images or illustrations in this brochure may include options or custom details.

Please note that as safety equipment specifications or standards vary by country, this aspect of your purchase will need to be completed by yourself and or your Riviera representative.

Please refer to your Riviera representative for specific warranty cover and the latest detailed list of inclusions and options prior to purchase.



## The Reassurance of owning a Riviera

What sets Riviera apart as one of the world's great luxury motor yacht builders?

Is it the devotion to quality, standard of materials used, the ocean-tested structural strength, unsurpassed ease of operation, or the stylish, handcrafted luxury finish? Or perhaps it's the famous culture of care that transforms owners into the 'Riviera family'.

The answer is all of the above, and more. Much, much more. Over 40 years and the building of over 5,600 luxury motor yachts, the 600-strong Riviera team have been on a continuous quest of evolution and refinement.

This remarkable heritage of knowledge matched by innovation allows us to marry the best of the time proven with the exciting and new. Witness our introduction of cutting edge touch screen digital technology and joystick maneuverability, which make navigating and operating a Riviera and Belize luxury motor yacht a relaxed and enjoyable experience.

Located on the Gold Coast, Queensland, our 14-hectare, state-of-the-art manufacturing facility is the largest facility of its kind in the Southern Hemisphere. Here we build on the notable Australian qualities of strength, practicality and love of water in the continent completely surrounded by three oceans and four seas.

Then we test our designs in some of the toughest offshore conditions on earth. Hardly surprising that Riviera luxury motor yachts command impressive resale values worldwide.

Today, you can choose from five individual designs that make up our fabulous collection of luxury motor yachts, the Riviera Flybridge, SUV, Sport Yacht or Sports Motor Yacht models, along with our more traditional Belize Collection. All will withstand virtually anything the elements and you can put them through, with poise and ease.

Naturally, we back this confidence with an industry-leading 5-year structural limited warranty. In addition, with all our Volvo Penta powered yachts, we offer a 5-year limited warranty covering helm station controls and multi-function displays, steering and propellers, plus pod drives and engines.

Life is too short for needless compromise. So when it comes time to invest in your next dream motor yacht, why settle for a lesser option when you can enjoy all that makes up a Riviera.









## Crafted with pride, with you in mind

Owner-care at Riviera and Belize is in a class of its own. Premium quality, professional and personal, it is all designed to be of the highest quality, in keeping with the world-class luxury motor yacht we are building specifically for you.

Like thousands of other happy owners, we are confident your every experience of dealing with us and our global representative team - from selecting your favoured options, electronics and decor, through to routine maintenance and repairs - will be conducted with the upmost respect and care.

Our highly skilled team consult and partner with internationally acclaimed naval architects, designers and engineers to ensure we fully embrace the latest, most exciting industry standards and trends.

Constant communication with the worldwide family of Riviera owners also plays a vital part in helping guide and inform our new model development program.

All this pride in performance ensures Riviera will continue to exceed the evolving needs of discerning luxury motor yacht enthusiasts like you.

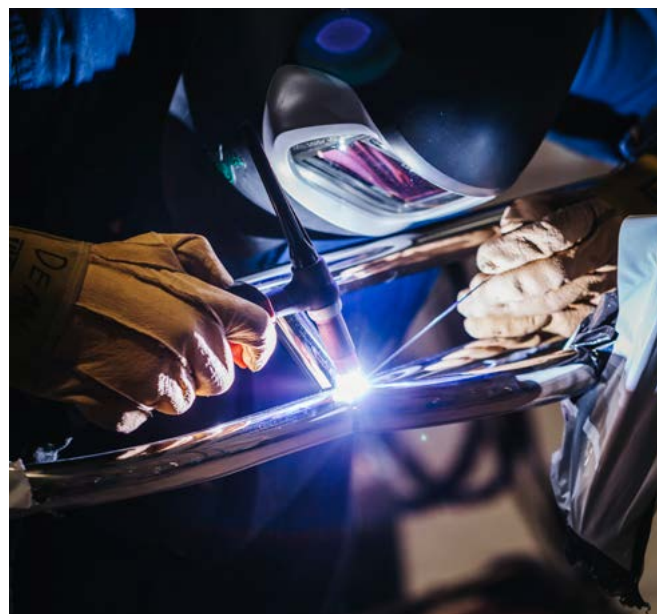



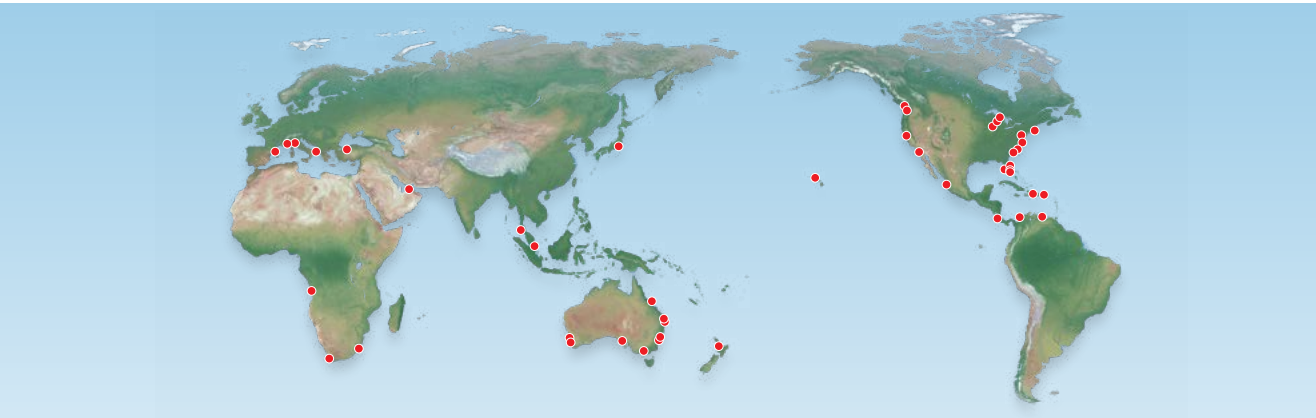

## A global marque of excellence

For nearly four decades the Riviera team have been preoccupied with the relentless pursuit of excellence. That means never being satisfied with the status quo, rather forever looking to improve and refine our knowledge base by embracing the latest technologies and work practices.

All these endeavours by our factory team and international representative network are directed towards creating a superior luxury motor yacht experience for you. They have also garnered us enormous acclaim from the global boating industry along the way.

Over the past four decades Riviera have accumulated an impressive collection of local, national and international awards recognising 'world's best practice' across the fields of education and training, employment, innovative manufacturing techniques, export, quality of workmanship and pioneering design.

More than testimony to our passion for handcrafting superior luxury motor yachts, they are your assurance when you decide to own a Riviera motor yacht.



## Electronics and systems

Electronics play an ever-increasing role in maximising the pleasure and safety of luxury motor yachts, and the choice of equipment that is available today is vast.

Selecting the equipment that meets your needs can be a very challenging task — and Riviera's electronics experts are here to assist.

We source the best systems from around the world, we help match technology to individual requirements and work closely with Riviera's international representative network to create systems that maximise your boating pleasure.

## Genuine Parts, Decor and Accessories

Our passion for quality and practical design is reflected in our exclusive and growing range of clothing, accessories and décor items created to enhance your time afloat.

If you love your Riviera, you'll feel right at home with the Riviera Collection — an extensive range of casual, stylish, comfortable, practical equipment, clothing and accessories.

The Accessory and Décor collection ranges from storm jackets to stylish crockery.

To make your Riviera truly your own, we offer a wide range of fabrics, finishes and colour schemes that enable you to personalise your motor yacht.

Of course our experienced design team is always available to advise and assist you with your individual selection.

**[RivieraParts.com.au](http://RivieraParts.com.au)**





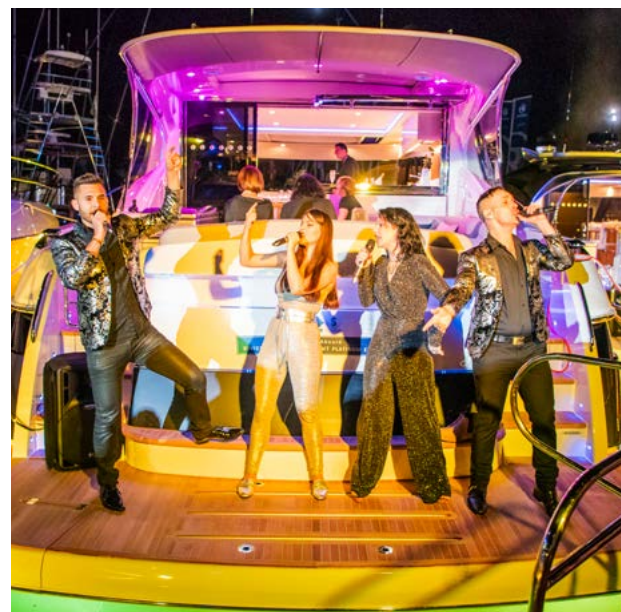

## The Riviera and Belize Experience

There's nothing quite like the exhilaration of blue-water cruising in company to remind our valued owners why they are so passionate about the rich and rewarding Riviera luxury life afloat.

For these are the types of passages that build the confidence and skills for people to use their yachts to their full potential, that create the very special memories that last a lifetime, and, importantly, are often the catalyst for long-lasting friendships.

Together, members of our growing global family of Riviera and Belize owners enjoy many special cruising experiences to idyllic destinations around the world — safe in the knowledge that experienced skippers and engineers are always close at hand.

We invite you to join with us for these special experiences — either to stretch your sea legs and gain offshore cruising confidence, or to simply enjoy the company of like-minded people who share an appreciation for the truly unique Riviera life.



# The Evolution of Riviera - Since 1980





# Constant refinement and innovation has created an Australian triumph



2018 - Belize 66 Sedan



2018 - 39 Sports Motor Yacht



2018 - 395 SUV



2018 - 72 Sports Motor Yacht



2017 - 68 Sports Motor Yacht



2016 - 4800 Sport Yacht



2016 - 575 SUV



2016 - 5400 Sport Yacht



2013 - 63 Open Flybridge



2013 - 50 Enclosed Flybridge



2012 - 445 SUV



2012 - 75 Enclosed Flybridge



2012 - Belize 54 Daybridge



2011 - Belize 54 Sedan



2011 - 4400 Sport Yacht SII



2011 - 61 Enclosed Flybridge SII



2008 - 56 Open Flybridge



2008 - 51 Enclosed Flybridge SII



2008 - 48 Offshore Express



2008 - 4400 Sport Yacht



2008 - 38 Open Flybridge



2007 - M470 Sport Cruiser



2007 - 4700 Sport Yacht



2007 - 45 Open Flybridge



2004 - 33 Open Flybridge



2003 - 58 Enclosed Flybridge



2003 - 47 Open Flybridge SII



2003 - 42 Open Flybridge



2002 - M370 Sport Cruiser



2002 - M290 Sport Cruiser



2002 - 47 Open Flybridge SI



2001 - M430 Sport Cruiser



1997 - 34 Open Flybridge



1997 - 4000 Offshore Enclosed



1997 - 4000 Offshore Open



1996 - 43 Open Flybridge



1996 - 40 Open Flybridge Aft Cab



1996 - 39 Open Flybridge



1995 - 3300 Open Flybridge



1993 - 48 Enclosed Flybridge SI



1988 - 52 Enclosed Flybridge



1987 - 35 Open Flybridge



1987 - 34 Diavalo



1987 - 33 Open Flybridge



1987 - 27 Open Flybridge



1986 - 38 Open Flybridge MK II



1985 - 52 Open Flybridge



1985 - 46 Open Flybridge





**RIVIERA**







